



+ info: <https://www.depadova.com/materials.pdf>
De Padova srl - info@depadova.it

CABINET

Materials

Carcass

blockboard panels veneered in Fossil oak or smoked oak, finished with transparent water-based or solvent-based coating. 45° edges in solid Fossil oak or smoked oak.

Drawers

blockboard, veneered in Fossil oak or smoked oak, finished with transparent water-based or solvent-based coating. Installed on runners with soft-close system.

Drawer fronts

blockboard, veneered in Fossil oak or smoked oak, finished with transparent water-based or solvent-based coating. Or in sheet in striped DeLabré G7 brass, striped DeLabré 7022 F12 stainless steel or DeLabré B E5 stainless steel. 45° edge and handle in solid wood.

Top

blockboard, veneered in Fossil oak or smoked oak, finished with transparent water-based or solvent-based coating. Or interior panel in structural aluminium covered by sheet in striped DeLabré G7 brass, striped DeLabré 7022 F12 stainless steel or DeLabré B E5 stainless steel. Or in Grey Stone, white Carrara marble, Calacatta Oro, Emperador Dark or grey Carnico - treated with water repellent products or finished with matt polyester. Or in MDI composite.

Base

matt black powder-coated steel and feet in burnished steel. Adjustable thermoplastic glide foot.

Feet

burnished steel. Adjustable thermoplastic glide foot.

SC16

Design:

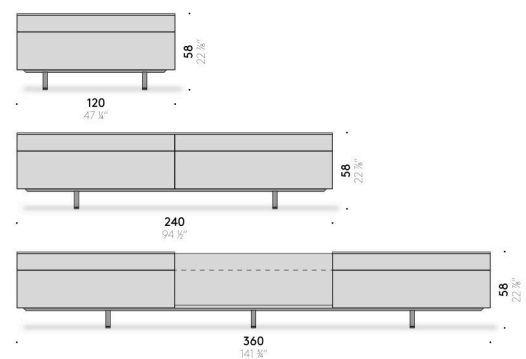
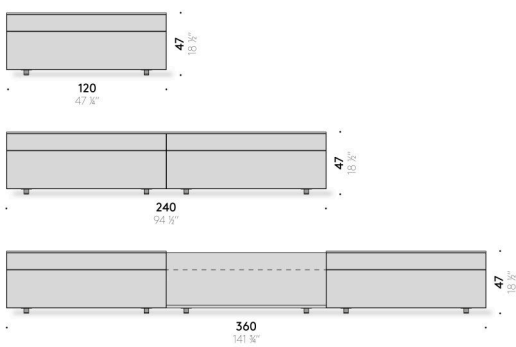
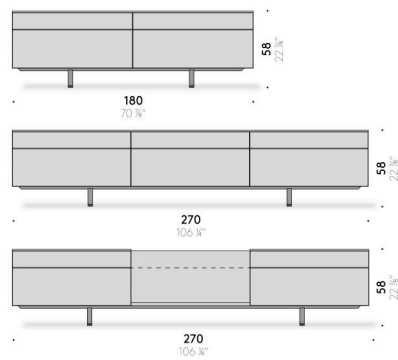
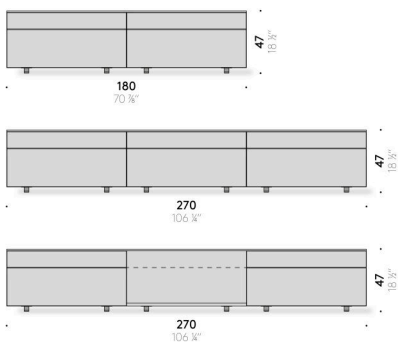
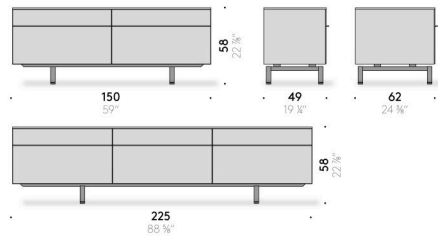
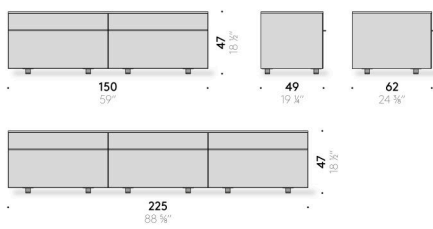



+ info: <https://www.depadova.com/materials.pdf>
De Padova srl - info@depadova.it

CONTENITORE

Materiali

Struttura contenitore

pannelli di listellare impiallacciati in Fossil oak o rovere affumicato, finiti con vernice trasparente a base acqua o a base solvente. Bordo a 45° in legno massello di Fossil oak o rovere affumicato.

Cassetti

listellare impiallacciato in Fossil oak o rovere affumicato, finiti con vernice trasparente a base acqua o a base solvente, montati su guide con meccanismo di ammortizzazione.

Frontali cassetti

listellare impiallacciato in Fossil oak o rovere affumicato, finiti con vernice trasparente a base acqua o a base solvente. Oppure in lamiera in Ottone DeLabré striato G7, Acciaio inox DeLabré striato 7022 F12 o Acciaio inox DeLabré B E5. Bordo a 45° e maniglia in massello di essenza.

Piano superiore

listellare impiallacciato con Fossil oak o rovere affumicato, finiti con vernice trasparente a base acqua o a base solvente. Oppure pannello interno in alluminio strutturale rivestito con lamiera in Ottone DeLabré striato G7, Acciaio inox DeLabré striato 7022 F12 o Acciaio inox DeLabré B E5. Oppure marmo Grey Stone, bianco Carrara, Calacatta Oro, Emperador Dark, Grigio Carnico finito a mano e trattato con prodotti idrorepellenti o finito con poliestere opaco. Oppure composito MDI.

Basamento

acciaio verniciato a polvere nero opaco e piede in acciaio brunito. Sottopiede regolabile in termoplastica.

Piedini

acciaio brunito. Sottopiede regolabile in termoplastica.

SC16

Design:

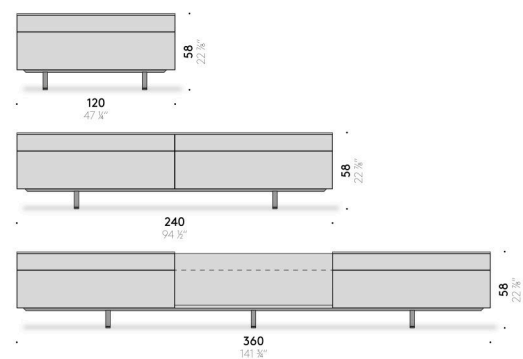
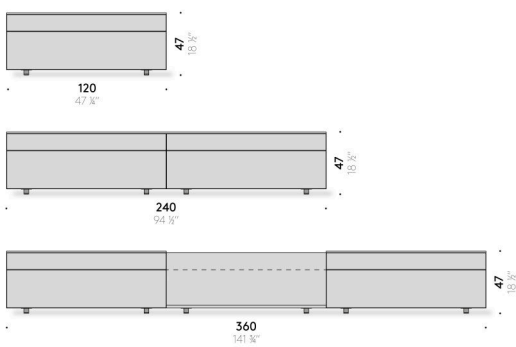
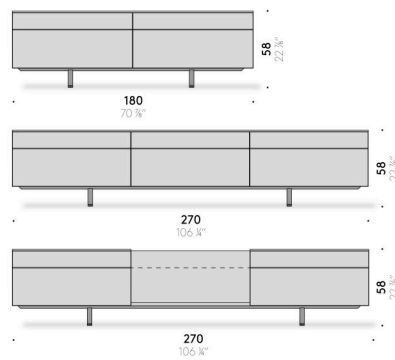
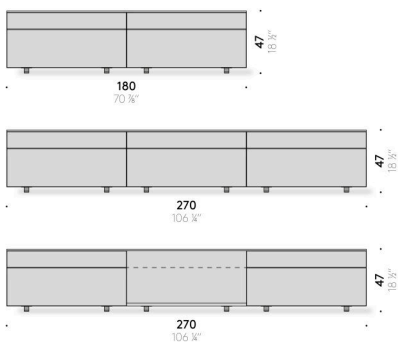
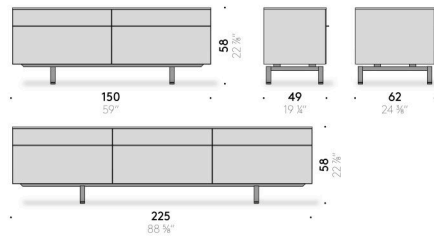
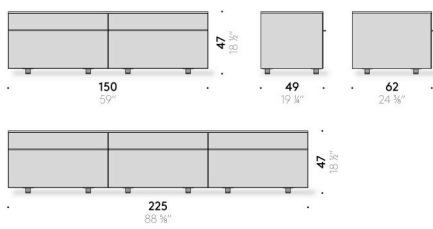



+ info: <https://www.depadova.com/materials.pdf>
De Padova srl - info@depadova.it

ELÉMENT DE RANGEMENT

Matériaux

Structure élément de rangement
panneaux de latté plaqués en Fossil oak ou chêne fumé, finis avec peinture transparente à l'eau ou à base de solvant. Bord à 45° en bois massif de Fossil oak ou chêne fumé.

Tiroirs

latté plaqué en Fossil oak ou chêne fumé, finis avec peinture transparente à l'eau ou à base de solvant, montés sur glissières avec mécanisme d'amortissement.

Façades tiroirs

panneau de latté plaqué en Fossil oak ou en chêne fumé, fini avec peinture transparente à l'eau ou à base de solvant. Ou panneau avec tôle en Laiton DeLabré strié G7, Acier inox DeLabré strié 7022 F12 ou Acier inox DeLabré B E5. Bord à 45° et poignée en massif d'essence.

Dessus supérieur

panneau de latté plaqué en Fossil oak ou en chêne fumé, fini avec peinture transparente à l'eau ou à base de solvant. Ou panneau interne en aluminium structurel revêtu avec tôle en Laiton DeLabré strié G7, Acier inox DeLabré strié 7022 F12 ou Acier inox DeLabré B E5. Ou marbre Grey Stone, blanc Carrara, Calacatta Oro, Emperador Dark, Gris Carnique fini à la main et traité avec des produits hydrofuges ou fini avec polyester mat. Ou composite MDI.

Embase

acier peint à poudre noir mat et pied en acier bruni. Patin réglable en thermoplastique.

Pieds

acier bruni. Patin réglable en thermoplastique.

SC16

Design:

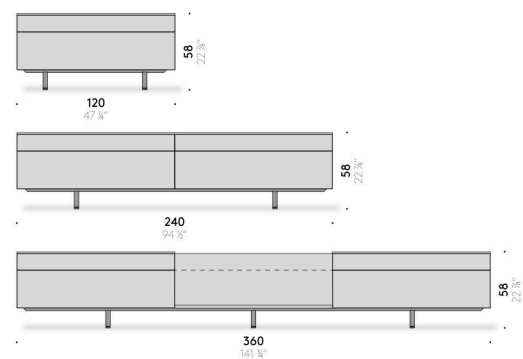
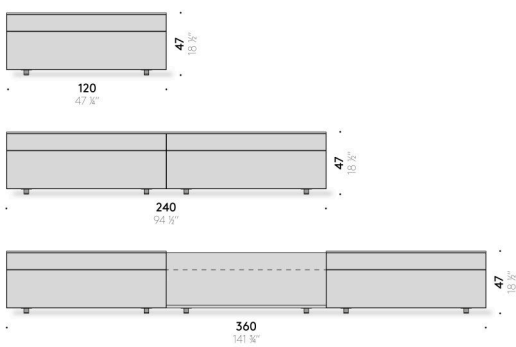
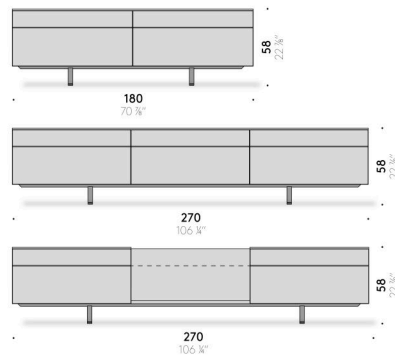
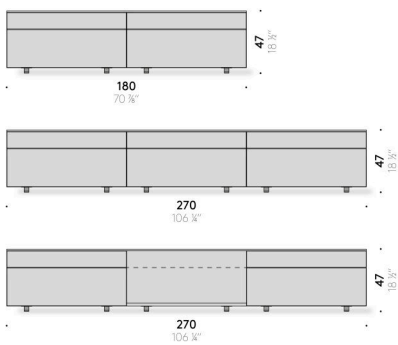
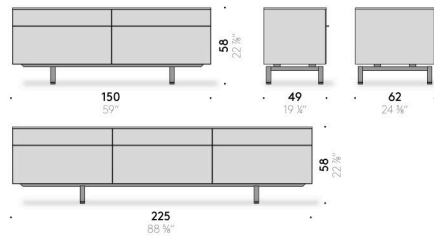
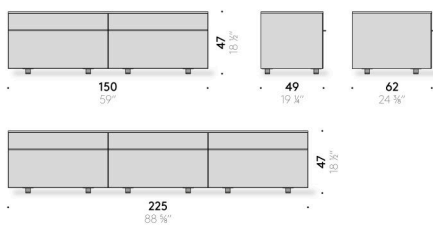



+ info: <https://www.depadova.com/materials.pdf>
De Padova srl - info@depadova.it

SCHRANKELEMENT

Materialien

Korpus

Tischlerplatten, furniert in Fossil oak oder Räuchereiche, endbehandelt mit transparentem Lack auf Wasser- oder Lösemittelbasis. Ecke 45° aus Massivholz Fossil oak oder Räuchereiche.

Schubladen

Tischlerplatte, furniert in Fossil oak oder Räuchereiche, endbehandelt mit transparentem Lack auf Wasser- oder Lösemittelbasis. Montiert auf Führungsschienen mit Einzugsdämpfer.

Schubladenfronten

Tischlerplatten, furniert in Fossil oak oder Räuchereiche, endbehandelt mit transparentem Lack auf Wasser- oder Lösemittelbasis. Oder hergestellt aus Blech in Messing gestreift DeLabré G7, Edelstahl gestreift DeLabré 7022 F12 oder Edelstahl DeLabré B E5. Ecke 45° und Griffe aus Massivholz.

Oberplatte

Tischlerplatte, furniert in Fossil Oak oder Räuchereiche, endbehandelt mit transparentem Lack auf Wasser- oder Lösemittelbasis. Oder Innenpaneel in Strukturaluminium verkleidet mit Blech in Messing gestreift DeLabré G7, Edelstahl gestreift DeLabré 7022 F12 oder Edelstahl DeLabré B E5. Oder Marmor Grey Stone, weißer Carrara-Marmor, Marmor Calacatta Oro, Emperador Dark oder Grau Carnico von Hand endbehandelt, und mit wasserabweisenden Produkten behandelt oder mit mattem Polyester beschichtet. Oder Verbundmaterial MDI.

Untergestell

Pulverlackiertes Stahlgestell mattschwarz und Fuß aus brüniertem Stahl. Verstellbarer Thermoplast-Gleitfuß.

Füße

aus brüniertem Stahl. Verstellbarer Thermoplast-Gleitfuß.

SC16

Design:

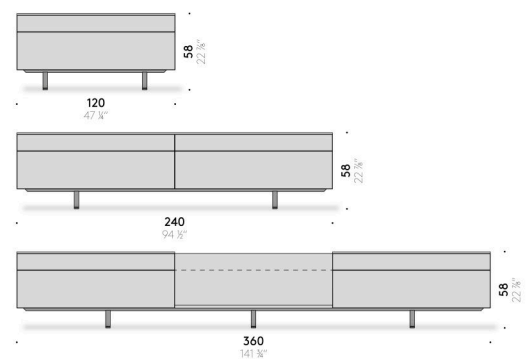
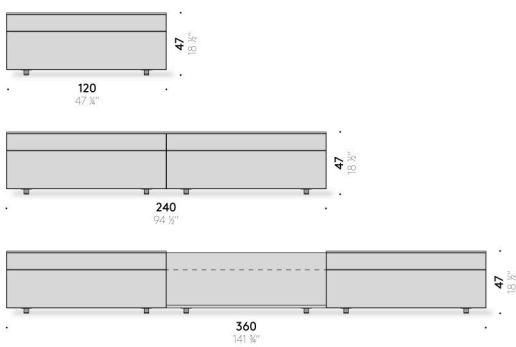
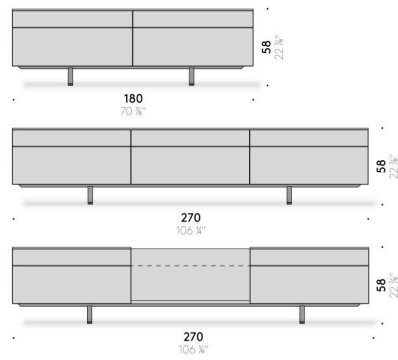
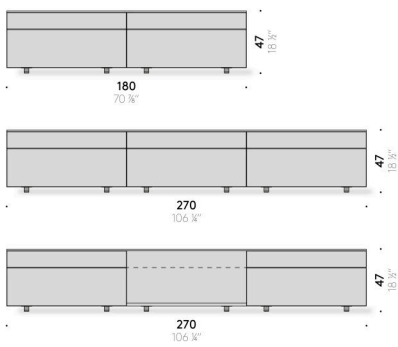
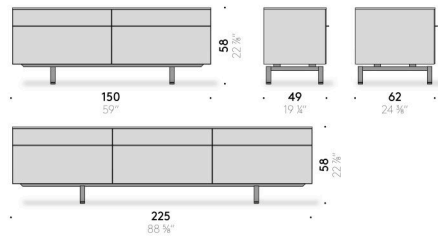
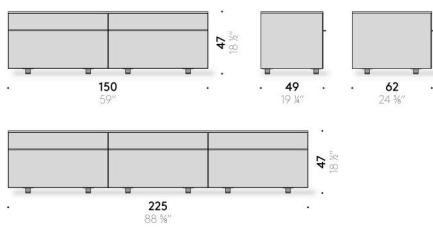



+ info: <https://www.depadova.com/materials.pdf>
De Padova srl - info@depadova.it

MUEBLE CONTENEDOR

Materiales

Estructura mueble contenedor

paneles de madera alistonada chapados en Fossil oak o roble ahumado, acabados con pintura transparente al agua o al disolvente. Borde en 45° de madera maciza de Fossil oak o roble ahumado.

Cajones

madera alistonada de Fossil oak o roble ahumado, acabados con barniz transparente al agua o al disolvente, montados sobre guías con mecanismo de amortiguación.

Frentes cajones

madera alistonada chapada con Fossil oak o roble ahumado, acabados con pintura transparente al agua o al disolvente. O con chapa de Latón DeLabré estriado G7, Acero inoxidable DeLabré estriado 7022 F12 o Acero inoxidable DeLabré B E5. Borde en 45° y tirador de madera maciza.

Tablero superior

madera alistonada chapada con Fossil oak o roble ahumado, acabados con pintura transparente al agua o al disolvente. O panel interior de aluminio estructural recubierto con chapa de latón DeLabré estriado G7, Acero inoxidable DeLabré estriado 7022 F12 o Acero inoxidable DeLabré B E5. O mármol Grey Stone, blanco Carrara, Calacatta Oro, Emperador Dark, Gris de Carnia acabado a mano y tratado con productos repelentes al agua o acabado con poliéster mate. O compuesto MDI.

Base

acero pintado en polvo negro mate y pie de acero bruñido. Bajo-pie ajustable de termoplástico.

Pies

acero bruñido. Bajo-pie ajustable de termoplástico.

SC16

Design:

