

SC16

2016



+ info: <https://www.depadova.com/materials.pdf>
De Padova srl - info@depadova.it

CABINET

Materials

Carcass

blockboard panels veneered in Fossil oak or smoked oak, finished with transparent water-based or solvent-based coating. 45° edges in solid Fossil oak or smoked oak.

Drawers

blockboard, veneered in Fossil oak or smoked oak, finished with transparent water-based or solvent-based coating. Installed on runners with soft-close system.

Drawer fronts

blockboard, veneered in Fossil oak or smoked oak, finished with transparent water-based or solvent-based coating. Or in sheet in striped DeLabré G7 brass, striped DeLabré 7022 F12 stainless steel or DeLabré B E5 stainless steel. 45° edge and handle in solid wood.

Top

blockboard, veneered in Fossil oak or smoked oak, finished with transparent water-based or solvent-based coating. Or interior structural aluminium panel covered by sheet in striped DeLabré G7 brass, striped DeLabré 7022 F12 stainless steel or DeLabré B E5 stainless steel. Or in hand-finished marble treated with water-repellent products or finished with matt polyester. Or in MDI composite.

Base

matt black powder-coated steel and feet in burnished steel. Adjustable thermoplastic glide foot.

Feet

burnished steel. Adjustable thermoplastic glide foot.

SC16

2016

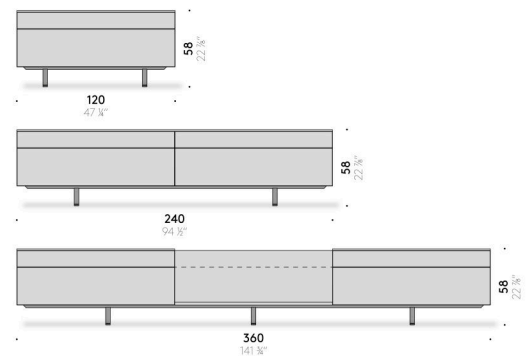
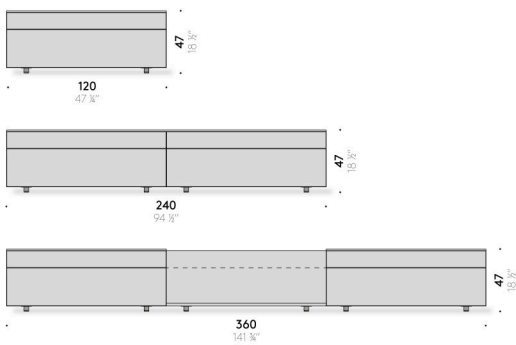
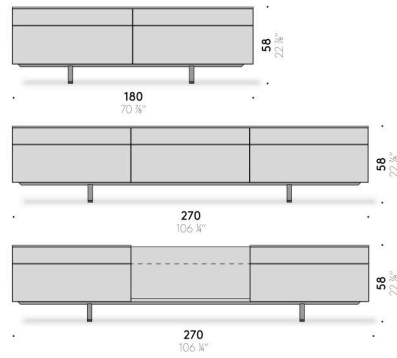
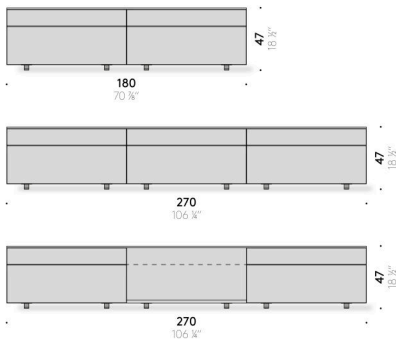
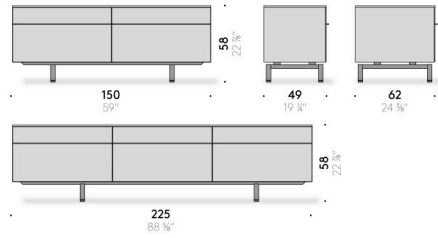
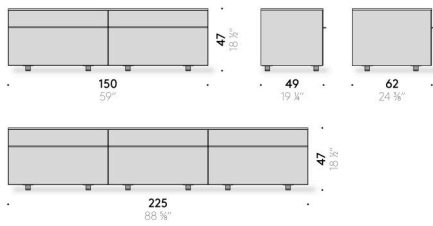

SC16

2016



+ info: <https://www.depadova.com/materials.pdf>
De Padova srl - info@depadova.it

CONTENITORE

Materiali

Struttura contenitore

pannelli di listellare impiallacciati in Fossil oak o rovere affumicato, finiti con vernice trasparente a base acqua o a base solvente. Bordo a 45° in legno massello di Fossil oak o rovere affumicato.

Cassetti

listellare impiallacciato in Fossil oak o rovere affumicato, finiti con vernice trasparente a base acqua o a base solvente, montati su guide con meccanismo di ammortizzazione.

Frontali cassetti

listellare impiallacciato in Fossil oak o rovere affumicato, finiti con vernice trasparente a base acqua o a base solvente. Oppure in lamiera in Ottone DeLabré striato G7, Acciaio inox DeLabré striato 7022 F12 o Acciaio inox DeLabré B E5. Bordo a 45° e maniglia in massello di essenza.

Piano superiore

listellare impiallacciato con Fossil oak o rovere affumicato, finiti con vernice trasparente a base acqua o a base solvente. Oppure pannello interno in alluminio strutturale rivestito con lamiera in Ottone DeLabré striato G7, Acciaio inox DeLabré striato 7022 F12 o Acciaio inox DeLabré B E5. Oppure marmo finito a mano e trattato con prodotti idrorepellenti o finito con poliestere opaco. Oppure composito MDI.

Basamento

acciaio verniciato a polvere nero opaco e piede in acciaio brunito. Sottopiede regolabile in termoplastica.

Piedini

acciaio brunito. Sottopiede regolabile in termoplastica.

SC16

2016

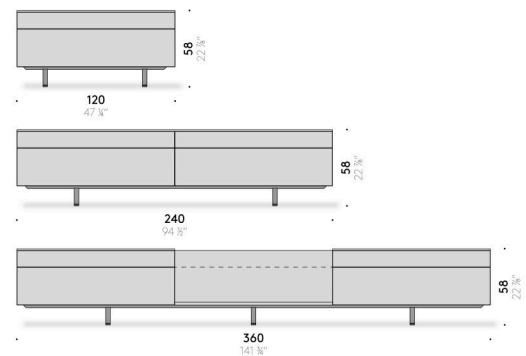
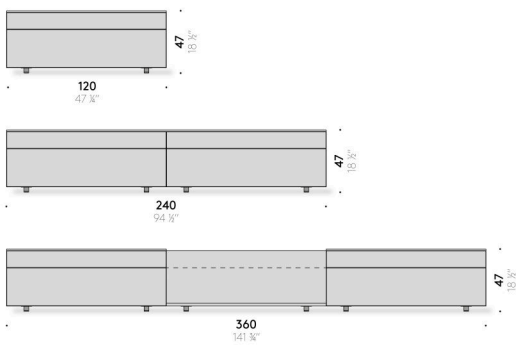
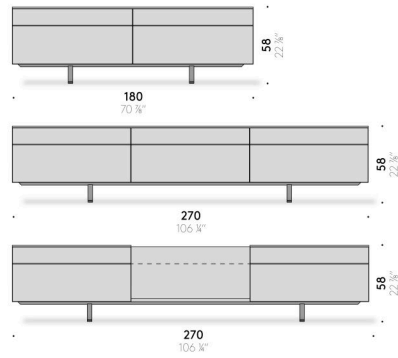
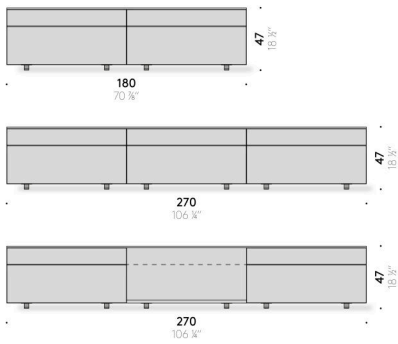
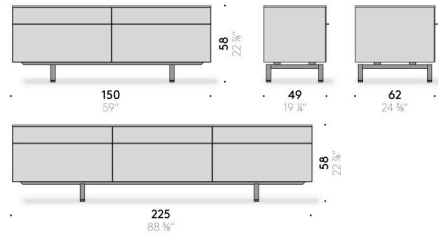
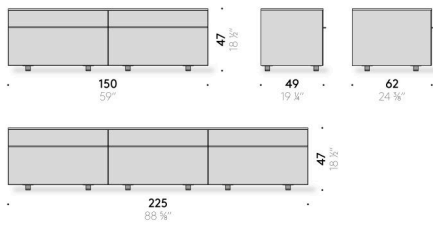

SC16

2016



+ info: <https://www.depadova.com/materials.pdf>
De Padova srl - info@depadova.it

ÉLÉMENT DE RANGEMENT

Matériaux

Structure élément de rangement
panneaux de latté plaqués en Fossil oak ou chêne fumé, finis avec peinture transparente à l'eau ou à base de solvant. Bord à 45° en bois massif de Fossil oak ou chêne fumé.

Tiroirs

latté plaqué en Fossil oak ou chêne fumé, finis avec peinture transparente à l'eau ou à base de solvant, montés sur glissières avec mécanisme d'amortissement.

Façades tiroirs

panneau de latté plaqué en Fossil oak ou en chêne fumé, fini avec peinture transparente à l'eau ou à base de solvant. Ou panneau avec tôle en Laiton DeLabré strié G7, Acier inox DeLabré strié 7022 F12 ou Acier inox DeLabré B E5. Bord à 45° et poignée en massif d'essence.

Dessus supérieur

panneau de latté plaqué en Fossil oak ou en chêne fumé, fini avec peinture transparente à l'eau ou à base de solvant. Ou panneau intérieur en aluminium structurel revêtu de tôle en Laiton DeLabré strié G7, Acier inoxydable DeLabré strié 7022 F12 ou en Acier Inox DeLabré B E5. Ou marbre fini à la main et traité avec des produits hydrofuges ou fini avec du polyester mat. Ou composite MDI.

Embase

acier peint à poudre noir mat et pied en acier bruni. Patin réglable en thermoplastique.

Pieds

acier bruni. Patin réglable en thermoplastique.

SC16

2016

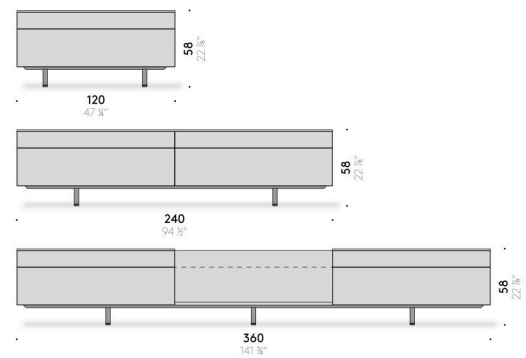
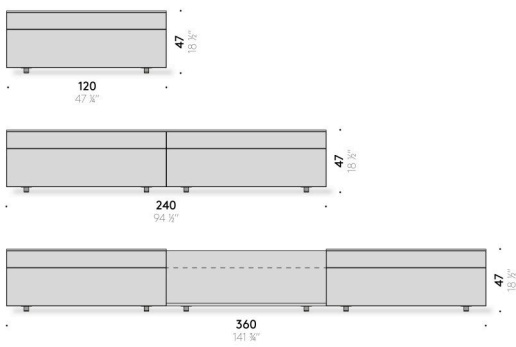
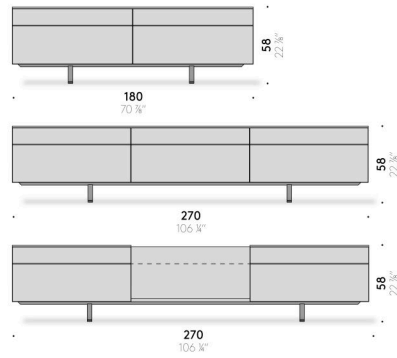
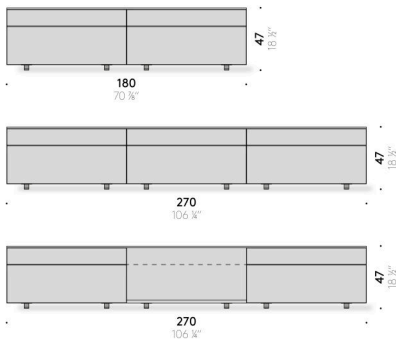
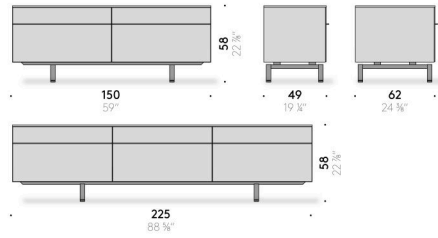
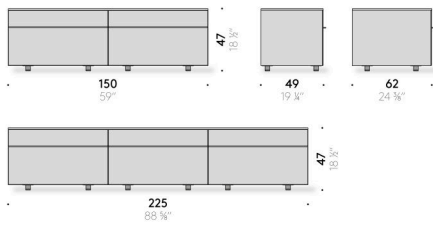

SC16

2016



+ info: <https://www.depadova.com/materials.pdf>
De Padova srl - info@depadova.it

SCHRANKELEMENT

Materialien

Korpus

Tischlerplatten, furniert in Fossil oak oder Räumereiche, endbehandelt mit transparentem Lack auf Wasser- oder Lösemittelbasis. Ecke 45° aus Massivholz Fossil oak oder Räumereiche.

Schubladen

Tischlerplatte, furniert in Fossil oak oder Räumereiche, endbehandelt mit transparentem Lack auf Wasser- oder Lösemittelbasis. Montiert auf Führungsschienen mit Einzugsdämpfer.

Schubladenfronten

Tischlerplatten, furniert in Fossil oak oder Räumereiche, endbehandelt mit transparentem Lack auf Wasser- oder Lösemittelbasis. Oder hergestellt aus Blech in Messing gestreift DeLabré G7, Edelstahl gestreift DeLabré 7022 F12 oder Edelstahl DeLabré B E5. Ecke 45° und Griffe aus Massivholz.

Oberplatte

Tischlerplatte, furniert in Fossil Oak oder Räumereiche, endbehandelt mit transparentem Lack auf Wasser- oder Lösemittelbasis. Oder Innenpaneel in Strukturaluminium verkleidet mit Blech in Messing gestreift DeLabré G7, Edelstahl gestreift DeLabré 7022 F12 oder Edelstahl DeLabré B E5. Oder handgefertigter Marmor, der mit wasserabweisenden Produkten behandelt oder mit mattem Polyester beschichtet wurde. Oder Verbundmaterial MDI.

Untergestell

Pulverlackiertes Stahlgestell mattschwarz und Fuß aus brüniertem Stahl. Verstellbarer Thermoplast-Gleitfuß.

Füße

aus brüniertem Stahl. Verstellbarer Thermoplast-Gleitfuß.

SC16

2016

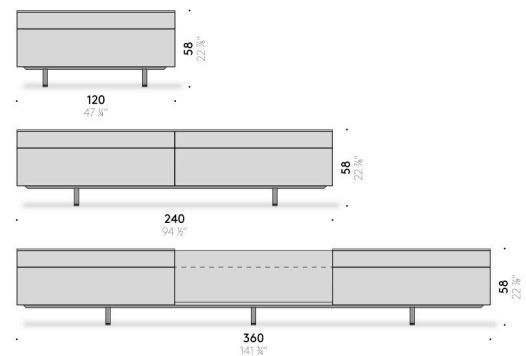
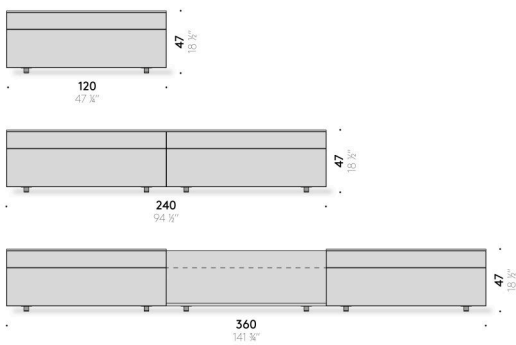
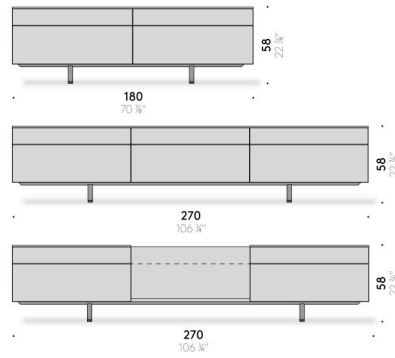
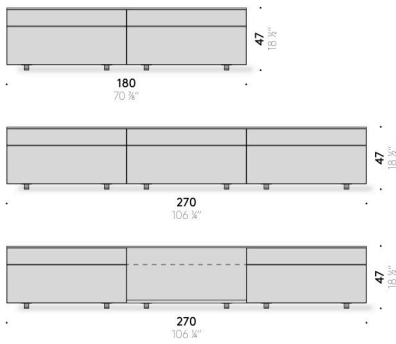
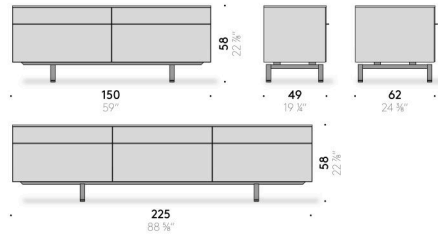
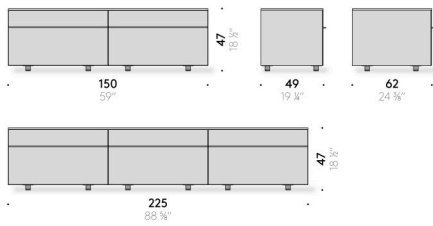



+ info: <https://www.depadova.com/materials.pdf>
De Padova srl - info@depadova.it

MUEBLE CONTENEDOR

Materiales

Estructura mueble contenedor

paneles de madera alistonada chapados en Fossil oak o roble ahumado, acabados con pintura transparente al agua o al disolvente. Borde en 45° de madera maciza de Fossil oak o roble ahumado.

Cajones

madera alistonada de Fossil oak o roble ahumado, acabados con barniz transparente al agua o al disolvente, montados sobre guías con mecanismo de amortiguación.

Frentes cajones

madera alistonada chapada con Fossil oak o roble ahumado, acabados con pintura transparente al agua o al disolvente. O con chapa de Latón DeLabré estriado G7, Acero inoxidable DeLabré estriado 7022 F12 o Acero inoxidable DeLabré B E5. Borde en 45° y tirador de madera maciza.

Tablero superior

madera alistonada chapada con Fossil oak o roble ahumado, acabados con pintura transparente al agua o al disolvente. O panel interior de aluminio estructural recubierto con chapa de latón DeLabré estriado G7, Acero inoxidable DeLabré estriado 7022 F12 o Acero inoxidable DeLabré B E5. O marmol acabado a mano y tratado con productos repelentes al agua o acabado con poliéster mate. O compuesto MDI.

Base

acero pintado en polvo negro mate y pie de acero bruñido. Bajo-pie ajustable de termoplástico.

Pies

acero bruñido. Bajo-pie ajustable de termoplástico.

SC16

2016

