

# Rea Paolo Tilche 1956

## Sedia e sgabello

### Materiali

STRUTTURA: acciaio verniciato a polvere color nero opaco.  
SEDUTA E SCHIENALE: rivestimento in cuoio pigmentato color naturale; oppure cuoio pieno fiore conciato al vegetale e tinto all'anilina color naturale.



+info:  
<http://www.depadova.com/materials.pdf>

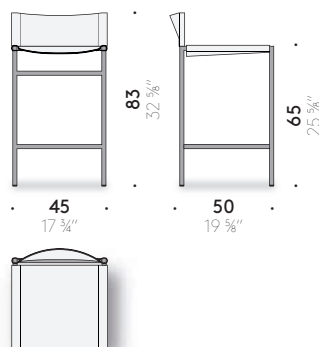
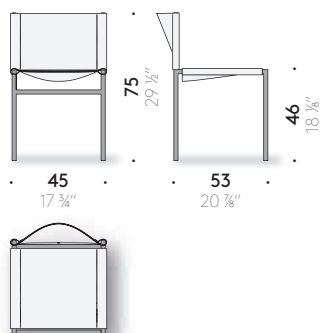

# Rea Paolo Tilche 1956

## Chair and stool

### Materials

FRAME: matt black powder-coated steel.

SEAT AND BACKREST: pigmented cowhide, natural colour; or full grain, vegetable-tanned and aniline-dyed cowhide, natural colour.



+info:

<http://www.depadova.com/materials.pdf>

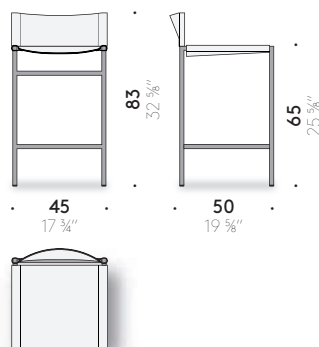
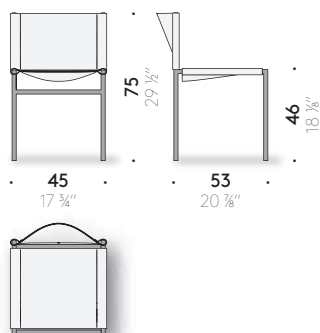

# Rea Paolo Tilche 1956

## Chaise et tabouret

### Matériaux

STRUCTURE: acier peint noir mat à poudre.  
ASSISE ET DOSSIER: revêtement en cuir pigmenté couleur naturel ;  
ou cuir pleine fleur tanné végétal et teinté à l'aniline couleur naturel.



+info:  
<http://www.depadova.com/materials.pdf>

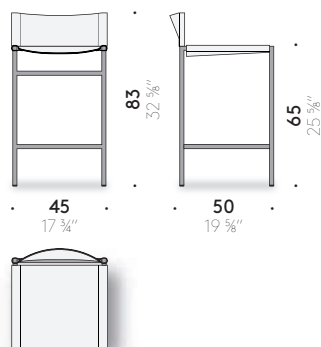
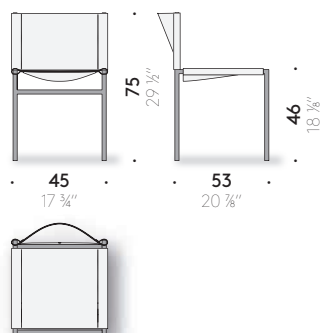

# Rea Paolo Tilche 1956

## Stuhl und Hocker

### Materialien

GESTELL: Stahl mit Pulverlackierung, matt schwarz.  
SITZ UND RÜCKENLEHNE: Kernlederbezug pigmentiert naturfarben; oder aus pflanzlich gegerbtem vollnarbigem und anilin-gefärbtem Kernleder naturfarben.



+info:  
<http://www.depadova.com/materials.pdf>

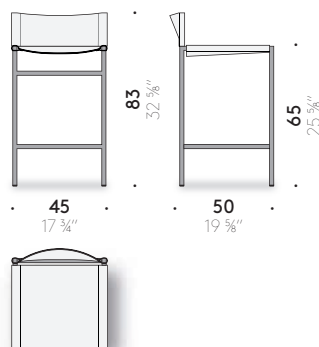
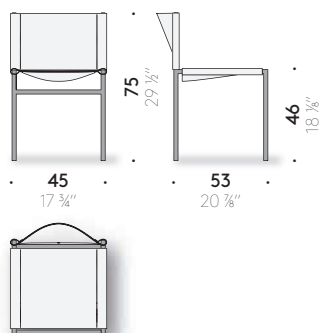

# Rea Paolo Tilche 1956

## Silla y taburete

### Materiales

ESTRUCTURA: acero pintado en polvo color negro mate.  
ASIENTO Y RESPALDO: revestimiento en cuero pigmentado color natural; o cuero plena flor curtido al vegetal y teñido a la anilina color natural.



+info:  
<http://www.depadova.com/materials.pdf>

