

R.I.G. Table Mikal Harrsen and Adam Hall 2012



Tavolo

Materiali:

BASE: profili in acciaio pieno verniciato a polvere color nero gofrato oppure verniciato a liquido color ottone.

PIANO IN CDF IMPIALLACCIATO, CDF PLACCATO: pannello in fibre di legno ad alta densità (CDF - certificato classe E1, CARB P2 / TSCA Title VI) nero opaco impiallacciato in rovere naturale o rovere affumicato, finito con vernice trasparente a poro aperto a base acqua o a base solvente, oppure placcato con superficie nanotecnologica Fenix NTM® "soft touch" color bianco Kos, grigio Londra o nero Ingo. Bordo nero a vista.

PIANO IN VETRO: vetro extrachiario, temperato, bordo filo lucido.

+info:
<http://www.depadova.com/maustudio-materials.pdf>

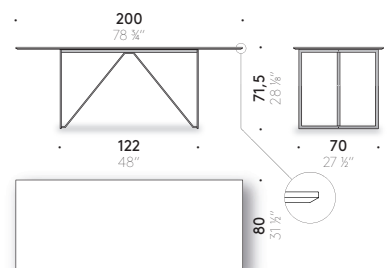
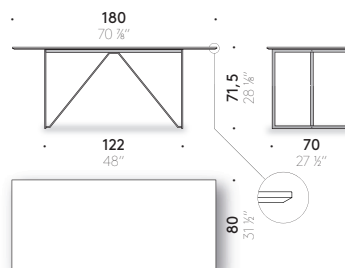
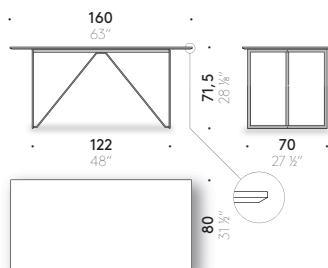
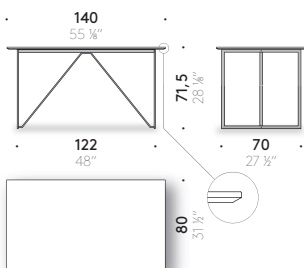
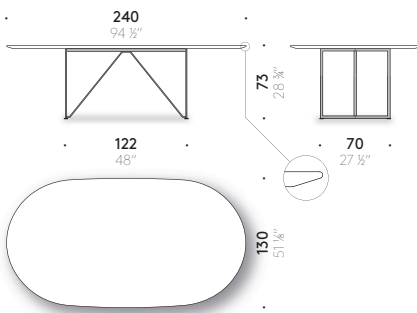

R.I.G. Table

Mikal Harrsen and Adam Hall 2012



Table

Materials:

BASE: profiles in solid steel, powder-coated (embossed black) or liquid painted (brass).

TOP IN CDF VENEER, CDF COATED: matt black high-density wood fibres panels (CDF - class E1, CARB P2 /TSCA Title VI certified), veneered in natural or smoked oak, then finished with transparent open-pore water-based or solvent-based coating; or coated in "soft touch" Fenix NTM® (nanotechnology surface) in Kos white, Londra grey or Ingo black. Visible black edge.

TOP IN GLASS: extra clear glass, tempered, with polished edge.

+info:
<http://www.depadova.com/maustudio-materials.pdf>

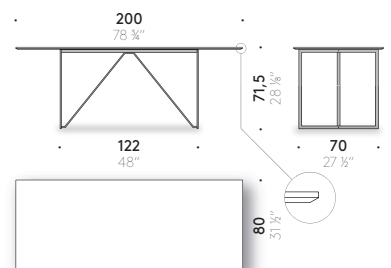
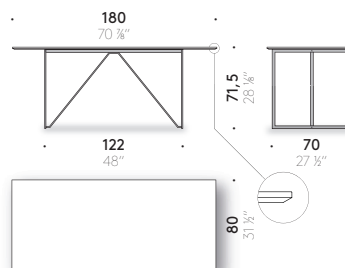
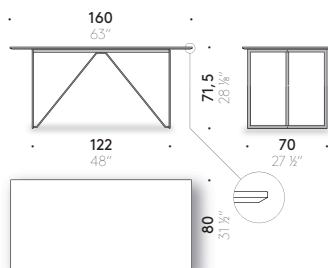
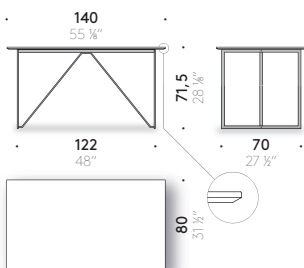
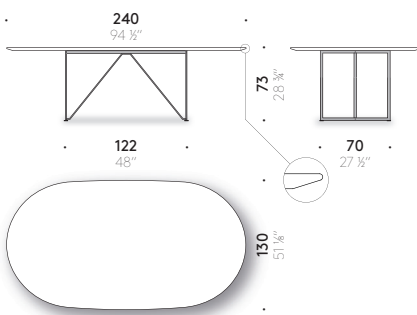

R.I.G. Table

Mikal Harrsen and Adam Hall 2012



Table

Matériaux:

BASE: profilés en acier plein peint à poudre couleur noir gauffré ou laqué liquide couleur laiton.

DESSUS EN CDF PLAQUÉ, CDF REVÊTU: panneau en fibres de bois à haute densité (CDF - certifié classe E1, CARB P2 / TSCA Title VI) noir mat plaqué en chêne naturel ou chêne fumé, fini avec peinture transparente à pores ouverts à l'eau ou à base de solvant, ou plaqué avec surface nanotechnologique Fenix NTM® "soft touch" couleur blanc Kos, gris Londra ou noir Ingo. Chant noir apparent.

DESSUS EN VERRE: verre extraclair, trempé, bords polis.

+info:
<http://www.depadova.com/maustudio-materials.pdf>

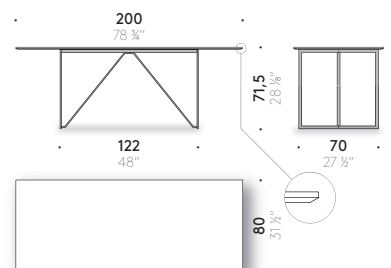
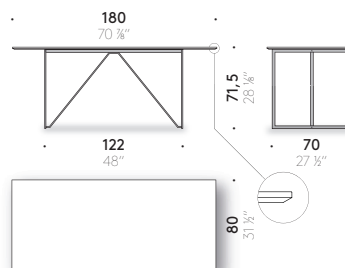
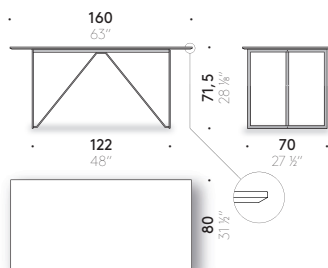
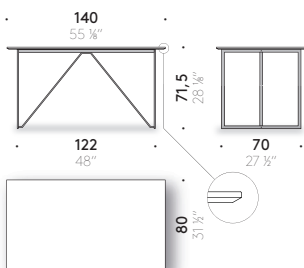
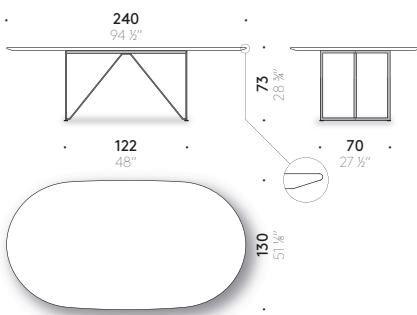

R.I.G. Table

Mikal Harrsen and Adam Hall 2012



Tisch

Materialien:

UNTERGESTELL: Profile aus massivem Stahl, pulverlackiert (schwarz gaufriert) oder nasslackiert (Messing).

TISCHPLATTE AUS CDF FURNIERT, CDF BESCHICHTET: Paneel aus kompakt verdichteter, matt schwarz eingefärbter Faserplatte (CDF - zertifiziert Klasse E1, CARB P2 / TSCA Title VI), furniert in Natureiche oder Räuchereiche, mit transparentem offenporigem Lack auf Wasser- oder Lösemittelbasis als Endbehandlung. Oder beschichtet mit schwarzer nanotechnologischer Oberfläche Fenix NTM® "soft touch" Farbe weiß Kos, grau Londra oder schwarz Ingo. Sichtbare schwarze Kante.

TISCHPLATTE AUS GLAS: extrahelles gehärtetes Glas, geätzt, mit geschliffener Kante poliert.

+info:
<http://www.depadova.com/maustudio-materials.pdf>

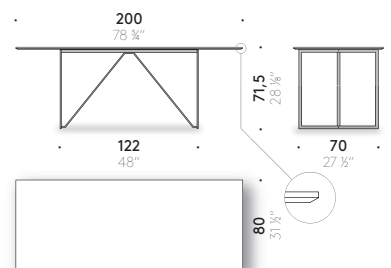
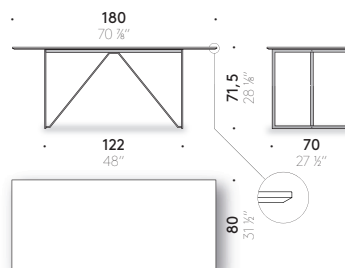
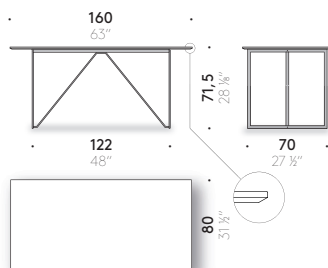
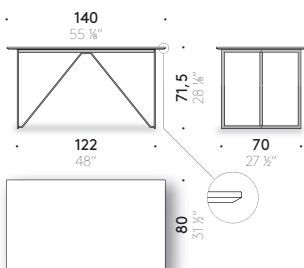
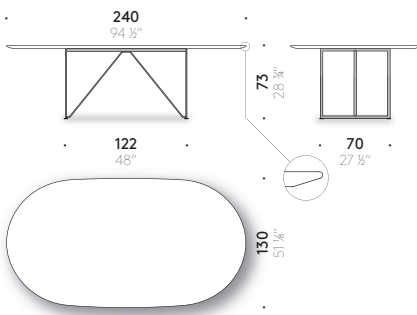

R.I.G. Table

Mikal Harrsen and Adam Hall 2012



Mesa

Materiales:

BASE: perfiles de acero lleno pintados con polvo color negro gofrado o pintado con líquido color latón.

TABLERO DE CDF CHAPADO, CDF REVESTIDO: panel de fibras de madera de alta densidad (CDF - certificado clase E1, CARB P2 / TSCA Title VI) negro mate chapado en roble natural o roble ahumado, acabado con pintura transparente de poro abierto a base de agua o a base disolvente, o revestido con superficie nanotecnológica Fenix NTM® "soft touch" color blanco Kos, gris Londra o negro Ingo. Borde negro visto.

TABLERO DE VIDRIO: vidrio extraclaro, templado, borde filo brillante.

+info:
<http://www.depadova.com/maustudio-materials.pdf>

